

Control & Coordination in Biochemical Networks: Introduction to the CSM Special Issue on Systems Biology

Systems theory and cell biology have enjoyed a long relationship, which, under the umbrella of systems biology, has received increasing attention in recent years. Systems biology is concerned with the dynamic behavior of biochemical reaction networks or *pathways* within cells and in cell populations.

The biologist's conception of a pathway shown in Figure 1 is equivalent to the control engineer's block diagram. A pathway map exhibits the names of the molecular components, whose interactions govern the basic cell functions. These cell functions include programmed cell death or *apoptosis*, *cell growth*, *cell differentiation*, the process by which a stem cell specializes to become, for instance, a liver cell, and *cell division*, the process by which a cell separates into two daughter cells.

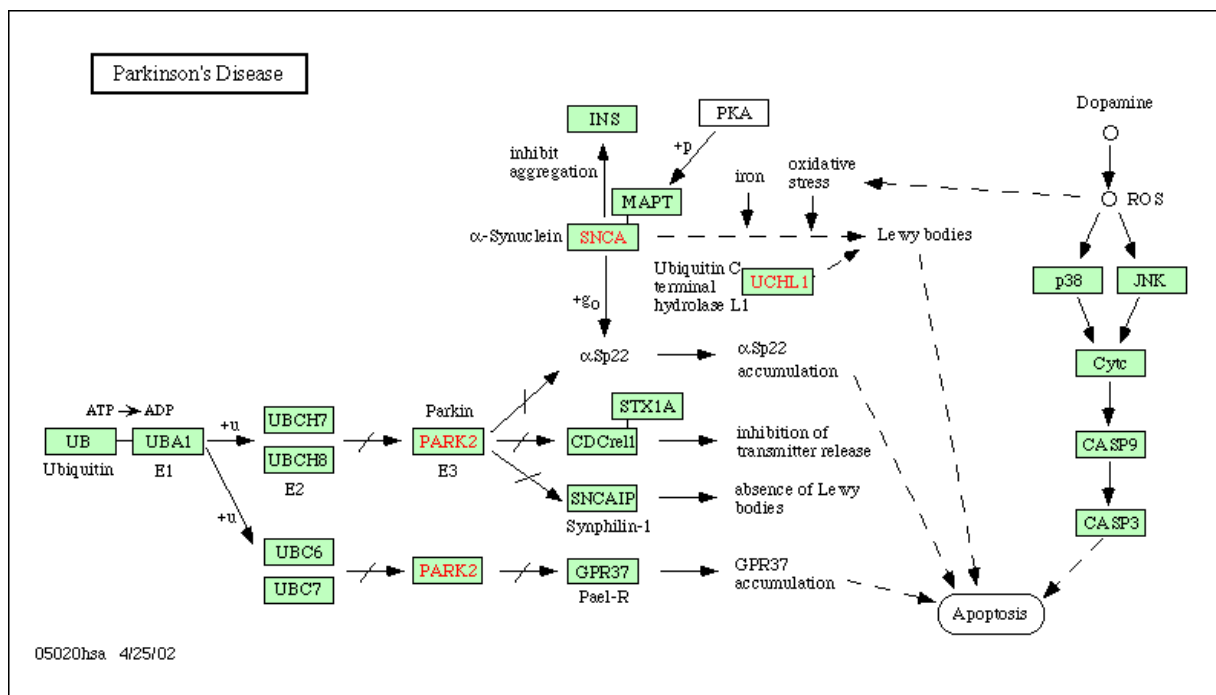

Figure 1: A typical pathway map. The map of this pathway for Parkinson's disease captures known proteins and their activation and inhibition relationships. Systems biology is concerned with the dynamic properties of biochemical networks underlying such pathway maps. (Reproduced with permission from the KEGG database <http://www.genome.ad.jp/kegg/>.)

Large numbers of pathway maps are collected in biological databases, and one motivation for systems biology is to bring these static diagrams to life by modeling and simulating the biochemical reactions that underlie cell function, organism development, and disease. The control engineering proficiency with block diagrams and modular representations contributes to systems biology by facilitating the translation of biological concepts into mathematical representations. The large number of variables in a typical pathway and the fact that these variables, which represent genes and proteins, usually occur in more than one process, suggest the need for modular representations. While modularity represents a reductionist approach to comprehending a complex system, there is evidence that molecular evolution coordinates the development of organizational building blocks, modules, and motifs. The modeling and discovery of this organization and the underlying coordination principles is one of the most important problems in systems biology.

On the surface, control engineers and cell biologists speak a similar language, sharing basic vocabulary such as “model,” “amplification,” “regulation,” “control,” “feedback,” and “nonlinear relationship”, although the interpretation is often rather different. The most obvious difference between these knowledge domains is the fact that control and regulation are implicit in biological processes, and thus it is usually not possible to identify a control unit as a separate process. Feedback loops are realized by the downstream release or removal proteins, which act further up in a pathway, see Figure 2.

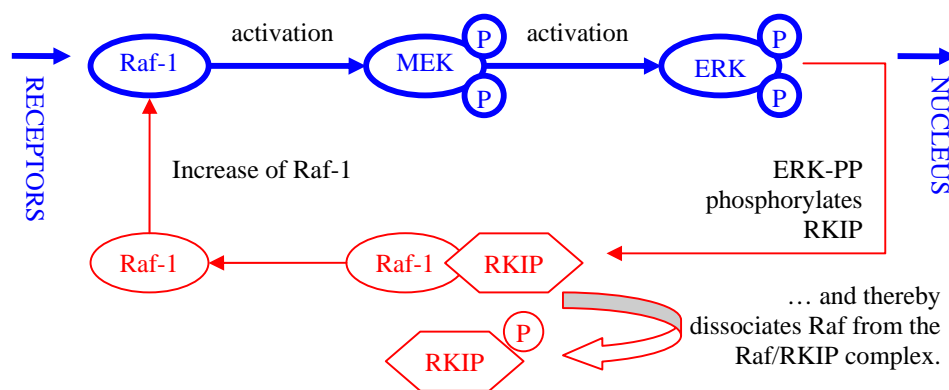

Figure 2: A positive feedback loop in a signal transduction pathway. The main pathway, which is indicated by the thick blue lines, is realized by the sequential activation of Raf-1, upstream near the cell membrane, followed by activation of the proteins MEK and ERK through structural modifications in the form of phosphorylations indicated by the P's. Double phosphorylated ERK translocates into the nucleus of the cell, where it effects the transcription of genes. ERK-PP also phosphorylates RKIP and releases Raf from the Raf-1/RKIP complex, and Raf in turn activates MEK. This positive feedback loop, indicated in red, leads to switch-like behavior of the pathway. Negative feedback loops on the other hand can lead to oscillations in signaling pathways.

The reproductive *cell-cycle* of a cell is an orderly sequence of events by which the cell duplicates and divides itself. This process implies periodic activity of genes and cyclic changes in protein concentrations. Data obtained for this process caught the early attention of modelers. The other area for which mathematical modeling has already established a track record in systems biology is *cell signaling* (Figure 3). To combine into networks, such as tissue and organs, that realize higher levels of organization, cells must communicate. The physical interface between the inside and outside of a cell is comprised, amongst other things, of *receptors*, which can sense extracellular signals and transmit the information to the genome to effect the transcription of genes. The biochemical reactions that relay signals are organized as networks in which feedback loops play a central role, see Figure 2. Not surprisingly then, bistable and oscillatory behavior has been observed in cell signaling. Cell signaling is closely associated with basic cell functions, such as proliferation, growth, and apoptosis. The consequences of failure in signaling are associated with cancer and neurodegenerative diseases.

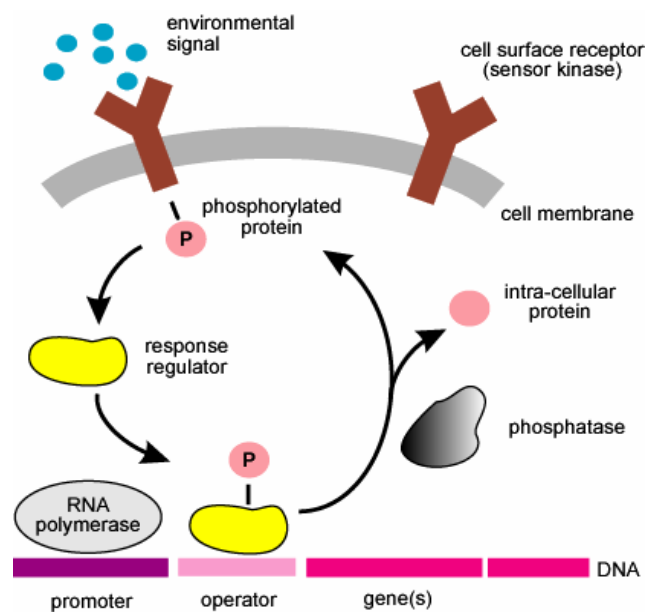

Figure 3: Cell signalling: Extracellular stimulation of receptors induces a series of intra-cellular biochemical reactions, relaying signals, and translocating proteins, which can alter the transcription of genes. Many cancer and neurodegenerative diseases are due to the failure of such communication at the molecular level.

A variable in a pathway model represents a population or concentration of a macromolecule in its particular physical state. Biochemical reactions can transform a molecule by changing the molecule's three-dimensional structure and thus its binding properties or by forming a complex with one or two other molecules. Mathematical models capture changes in molecule populations in space and time as well as the flow of material. The dynamic aspect has attracted the interest of the engineering community in systems biology, while the location, transport, and diffusion of molecules are important and challenging aspects of intra-cellular dynamics.

Unfortunately, it is not yet possible to generate quantitative and sufficiently rich time-series data from stimulus-response experiments to allow system identification in the traditional control-engineering sense. The successful combination of dynamic systems theory with molecular and cell biology requires the development of new technologies for quantitative, high-throughput experiments. Nevertheless, a growing number of publications demonstrate how mathematical modeling can support the generation and validation of hypotheses and guide the design of experiments. Although many biological processes involve a relatively large number of variables with complex interactions, even simple mathematical models can provide a conceptual framework for investigating inter- and intra-cellular dynamics.

Although the lack of stimulus-response data for system identification in the engineering sense is a reason for caution, this hurdle can be viewed as a source of interesting challenges waiting to be solved. Systems biology takes genomics and bioinformatics toward their natural conclusion, namely, an understanding of cellular function. Systems biology therefore promotes a shift of focus away from molecular characterization, identification, and cataloging of components, toward an understanding of the dynamic interactions that underlie cell functions as well as the development and functioning of tissue, organs, and organisms. With such an agenda one expects systems biology to be a long-term project that must avoid being just a buzzword. We must, therefore, remain realistic about the opportunities that mathematical modeling and simulation provide for enhancing biological understanding. We have no misconceptions that the engineering sciences have a readily available collection of tools and techniques waiting to be discovered by experimentalists; rather, biologically relevant technologies per se are needed to drive the development of a systems approach to cell biology.

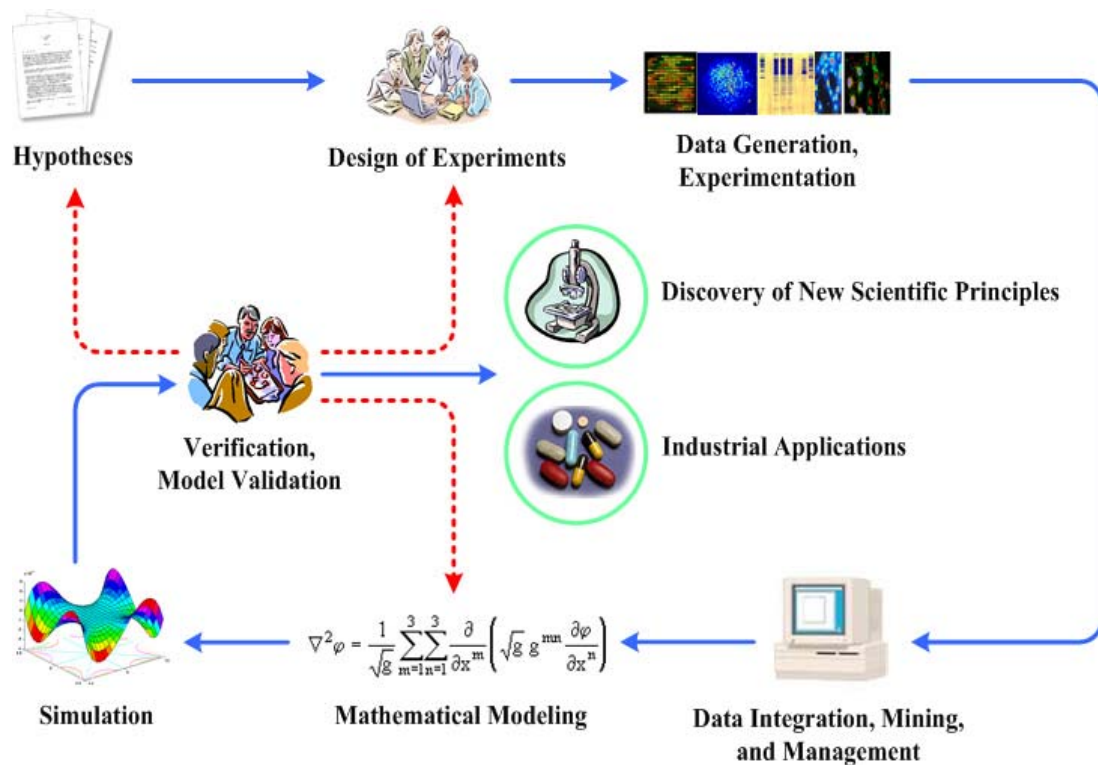

Figure 4: The iterative modeling process in systems biology. In contrast with many engineering projects, it is generally not possible in systems biology to separate the analysis of data from the context in which they are generated. Consequently, most experimental data are not directly suitable for parameter estimation and model structure selection. Missing information is typically extracted from the literature and experiments conducted in other laboratories. The modeling process requires close collaboration between theoreticians and experimentalists, beginning with the design of experiments well before data have been generated.

The complexity of cells as determined by the large number of variables that need to be considered, their nonlinear interactions, and the difficulties in observing molecular processes, forbids us to think of a precise virtual cell. Mathematical models in systems biology do not replicate the physical reality of molecules interacting in space and time, but rather provide an abstract representation of observable principles. While the area of bioinformatics is often associated with a flood of data, systems biology is characterized by a lack of quantitative stimulus-response time series. The lack of long time series data does not allow black-box modeling, where the quality of the model is assessed in terms of a prediction error. Instead, the structure of the model is of utmost importance as a reflection of biological knowledge. In fact, one interesting aspect of systems biology is the existence of publications that model the same process or pathway in very different frameworks, such as cellular automata, pi-calculus, and nonlinear ordinary differential equations. These communities effectively compete for the attention of biologists.

We believe that the most successful framework for theoretical biology will largely be determined by the interface between the theoretician and the experimentalist, rather than the model precision (Figure 4). The modeling process itself, the discussion between modeler and experimentalist, as to which variables to include in the model and their relationship is more important than the final product, that is, the predictive model. For example, in modeling signal transduction pathways, a key research question is to identify feedback loops and characterize their effect on protein concentration profiles. In this context it is not necessary to quantify the relevant effect by, for example, predicting a change of concentration to a fraction of a percent. Since many biological responses are smooth, a qualitative assessment of whether a signal is amplified, suppressed, delayed, or accelerated is often more useful.

The difficulties that exist in generating data for accurate and complete parameter estimation suggest new research directions. For example, we might seek modeling methodologies in which a lack of information about parameter values is accommodated by studying the temporal dependence of protein concentrations on changes to the model structure, in particular, the introduction or removal of feedback. What should be helpful is the fact that one often can assume bilinear relationships, while all variables and parameters are positive since the sign of terms is known or assumed, and thus the theory of monotone and positive systems is relevant.

The data generated in wet-labs are of crucial importance to the modeling process; in fact, ignoring the nature of data generated in the wet-lab without considering the particular technologies involved, usually renders a model useless for biologists. The necessary close interdisciplinary interaction between experimentalist and theoretician is a major challenge for systems biology to succeed. Control engineers have traditionally had no problem getting their hands dirty with real data, while at the same time they are not afraid to consider advanced mathematical techniques. The control engineering community should therefore be in a good position to make valuable contributions to the interdisciplinary endeavor of systems biology. To ensure success, it is important that questions relevant to biologists be addressed, and it is vital that the models reflect an appreciation for the experimental data.

On the other hand, it is important for biologists to become accustomed to systems thinking, and to promote the design of experiments that favor stimulus-response experiments over comparative studies. Supported by remarks from recent Nobel Prize winners in medicine and physiology, biologists are demonstrating an increased interest in mathematical modeling. There is a positive change of attitude toward interdisciplinary collaborations on both sides, and we are beginning to obtain technologies by which it is possible to quantify changes at the molecular level. It is time to realize systems biology.

In this special section we have gathered a selection of systems biology papers that consider issues relevant to the control engineering perspective of this field. The papers cover a range of biological systems, methodologies, and problems.

The contribution by Saez-Rodriguez and co-workers investigates the modular analysis of dynamics in signal transduction networks. Receptor-coupled signal transduction has emerged as a central theme in systems biology. While the following paper by Shvartsman focuses primarily on the receptor system, Saez-Rodriguez et al model the subsequent reactions within the cell. These articles are complementary.

Shvartsman et al consider the spatio-temporal dynamics of autocrine loops in a cell signaling system. With a wealth of information available for the EGF receptor system, this system provides a case study for systems biology. The conclusions of the paper emphasize the importance of studying the interactions between pathways, thereby highlighting the difficulties we have in isolating a subsystem for study.

Khammash and El-Sammad discuss how modeling on the gene level within cells relates to the physiology of an organism. The concept of *homeostasis* is described from a control engineering perspective using the regulation of calcium as a detailed case study. A second example considers the effect of stochasticity on feedback in a heat-shock regulatory system in bacterial systems.

The article by Paliwal et al describes the mechanism by which simple organisms sense spatial inhomogeneities in concentrations of chemical sources around them in order to move

toward the sources, a process known as *chemotaxis*. A model for a signaling mechanism that accounts for both the adaptation and spatial sensing properties displayed by chemotactic cells is based on the idea that the response is regulated by the balance between local excitation and global inhibition. The mathematical aspects of this paper are concerned with reaction-diffusion equations, an area influenced by Alan Turing's work in the 1950s.

Finally, the contribution by Schmidt and Jacobsen analyzes the impact of interactions within large scale biochemical networks. This article focuses on periodic phenomena and bistability, which underlie many important cell functions, such as circadian rhythms and the cell division cycle.

The editors wish to thank the referees and the Editor-in-Chief for their help in preparing this special section.

Olaf Wolkenhauer, University of Rostock, Germany

Olaf Wolkenhauer received degrees in control engineering from the University of Applied Sciences, Hamburg, Germany, and the University of Portsmouth, U.K., in 1994. He received his Ph.D. for work on possibility theory applied to data analysis in 1997 from the University of Manchester Institute of Science and Technology (UMIST) in Manchester, U.K. From 1997 to 2000 he was a lecturer in the Control Systems Centre, UMIST and held a joint senior lectureship between the Department of Biomolecular Sciences and the Department of Electrical Engineering & Electronics until 2003. He is now full professor (Chair in Systems Biology and Bioinformatics) in the Institute for Informatics at the University of Rostock, Germany. He is also a visiting professor in the Department of Mathematics at UMIST. His research interest is in data analysis and mathematical modeling with applications to molecular and cell biology. His research focus is on dynamic modeling of gene expression and cell signaling (www.sbi.uni-rostock.de).

Bijoy Ghosh, Washington University, USA

Bijoy K. Ghosh received his B.Tech and M.Tech degrees in Electrical and Electronics Engineering from India in 1977 and 1979, respectively. In 1983, he received his PhD in Engineering from the Division of Applied Sciences at Harvard University, Cambridge, USA. Since 1983, he has been a faculty member in the Department of Electrical and Systems Engineering at Washington University, St. Louis, where he is currently a Professor and directs

the center for BioCybernetics and Intelligent Systems. His research interests are in multivariable control theory, machine vision, robotics, biological control systems and systems biology. He has held short term visiting positions at the Indian Institute of Technology, Kharagpur, Tokyo Denki University, Tsukuba City, Osaka University, Tokyo Institute of Technology, Padova University, and Institut Mittag-Leffler. He is presently an elected member of the Board of Governors of the IEEE Control Systems Society, and is a chair of the technical committee on BioSystems and Control.

Kwang-Hyun Cho, University of Ulsan, South Korea

Kwang-Hyun Cho received his Ph.D. in electrical engineering from the Korea Advanced Institute of Science and Technology (KAIST) in 1998. He joined the School of Electrical Engineering at the University of Ulsan, Korea, in 1999, where he is an assistant professor. From June 2002 to August 2003, he worked in the Control Systems Centre of the Department of Electrical Engineering & Electronics at the University of Manchester Institute of Science and Technology (UMIST), U.K., as a Visiting Research Fellow. From January to March in 2004 he worked in the Automatic Control Group of the Department of Signals, Sensors and Systems at the Royal Institute of Technology, Sweden, as a visiting research fellow. His research interests cover the areas of systems science with bio-medical applications including systems biology, systems immunology, bio-medical informatics, biological systems identification, nonlinear dynamics, discrete event systems, and hybrid systems. His focus has been on applications in biotechnology and the bio-medical sciences, in particular, mathematical modeling and simulation of genetic- and signal transduction pathways, and microarray data analysis.

Sidebar:

For a concise account of cell biology see F.M. Harrold: *The Way of the Cell*. Oxford University Press, 2001. A more technical and comprehensive account of cell biology can be found in the textbook by Alberts et al entitled *Molecular Biology of the Cell*, fourth edition, Garland Science, 2002. A philosophical perspective on recent developments in cell biology, including issues relating to computational and systems modelling, is given by Evelyn Fox Keller in *Making Sense of Life*, Harvard University Press, 2002. A survey and introduction to systems biology is given in J.J.Tyson, K.C.Chen, and B.Novak, "Sniffers, Buzzers, Toggles and Blinkers: Dynamics of Regulatory and Signaling Pathways in the Cell," *Current Opinion in Cell Biology* 2003, **15**:221-231. Broad reviews of modeling approaches in molecular biology are given in H. De Jong, "Modeling and Simulation of Genetic Regulatory Systems: A Literature Review," *J. Comp. Biol.*, Vol.9, No.1, 2002, 67-103, and P. Smolen et al, "Modeling Transcriptional Control in Gene Networks – Methods, Recent Results, and Future Directions," *Bull. Math. Biol.* (2000) **62**, 247-292.